

SECTION **MT**

CONTENTS

PREPARATION	2	INSPECTION	15
Special Service Tools	2	Shift Control Components	15
Commercial Service Tools	3	Gear Components	15
ON-VEHICLE SERVICE	4	Gears And Shafts	15
Replacing Rear Oil Seal — 2WD Model	4	Synchronizers	15
Position Switch Check	4	Bearings	16
REMOVAL AND INSTALLATION	5	ASSEMBLY	17
MAJOR OVERHAUL	7	Gear Components	17
Case Components	7	Shift Control Components	23
Gear Components — 2WD Model	8	Case Components	24
Gear Components — 4WD Model	9	SERVICE DATA AND SPECIFICATIONS (SDS)	27
Shift Control Components	10	General Specifications	27
DISASSEMBLY	11	Inspection and Adjustment	28
Case Components	11		
Shift Control Components	11		
Gear Components	12		

PREPARATION

Special Service Tools

The actual shapes of Kent-Moore tools may differ from those of special service tools illustrated here.

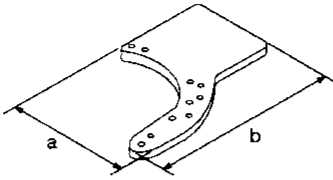
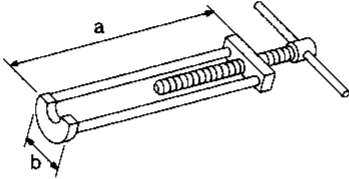
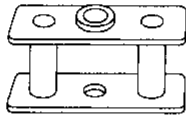
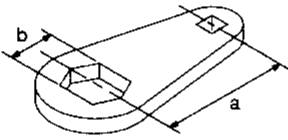
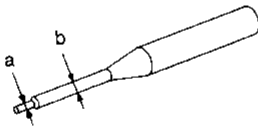
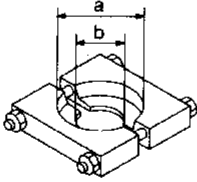
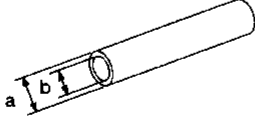
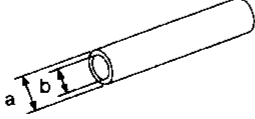
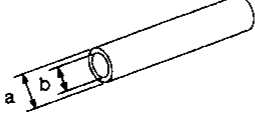
Tool number (Kent-Moore No.) Tool name	Description	
ST23810001 (—) Adapter setting plate	 <p>NT407</p>	Fixing adapter plate with gear assembly a: 166 mm (6.54 in) b: 270 mm (10.63 in)
KV32101330 (See J26349-A) Puller	 <p>NT408</p>	Removing overdrive mainshaft bearing a: 447 mm (17.60 in) b: 100 mm (3.94 in)
KV31100401 (—) Transmission press stand	 <p>NT068</p>	Pressing counter gear and mainshaft
ST22520000 (J26348) Wrench	 <p>NT409</p>	Tightening mainshaft lock nut a: 100 mm (3.94 in) b: 41 mm (1.61 in)
ST23540000 (J25689-A) Pin punch	 <p>NT442</p>	Removing and installing fork rod retaining pin a: 2.3 mm (0.091 in) dia. b: 4 mm (0.16 in) dia.
ST30031000 (J22912-01) Puller	 <p>NT411</p>	Removing and installing 1st gear bushing Removing main drive gear bearing a: 90 mm (3.54 in) dia. b: 50 mm (1.97 in) dia.
ST23860000 (—) Drift	 <p>NT065</p>	Installing counter drive gear a: 38 mm (1.50 in) dia. b: 33 mm (1.30 in) dia.
ST22360002 (J25679-01) Drift	 <p>NT065</p>	Installing counter gear front and rear end bearings a: 29 mm (1.14 in) dia. b: 23 mm (0.91 in) dia.
ST22350000 (J25678-01) Drift	 <p>NT065</p>	Installing OD gear bushing a: 34 mm (1.34 in) dia. b: 28 mm (1.10 in) dia.

PREPARATION

Special Service Tools (Cont'd)

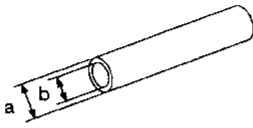
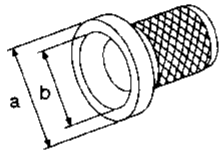
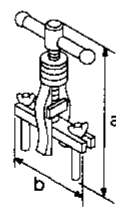
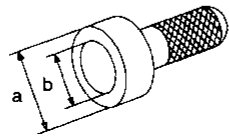
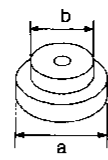
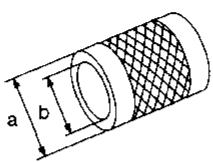
Tool number (Kent-Moore No.) Tool name	Description	
ST23800000 (J25691-01) Drift	 NT065	Installing front cover oil seal a: 44 mm (1.73 in) dia. b: 31 mm (1.22 in) dia.
ST33400001 (J26082) Drift	 NT086	Installing rear oil seal a: 60 mm (2.36 in) dia. b: 47 mm (1.85 in) dia.
ST33290001 (J34286) Puller	 NT414	Removing rear oil seal a: 250 mm (9.84 in) b: 160 mm (6.30 in)
ST30720000 (J25405) Drift	 NT115	Installing mainshaft ball bearing a: 77 mm (3.03 in) dia. b: 55.5 mm (2.185 in) dia.
ST30613000 (J25742-3) Drift	 NT073	Installing main drive gear bearing a: 71.5 mm (2.815 in) dia. b: 47.5 mm (1.870 in) dia.
ST33200000 (J26082) Drift	 NT091	Installing counter rear bearing a: 60 mm (2.36 in) dia. b: 44.5 mm (1.752 in) dia.

Commercial Service Tools

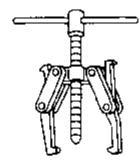
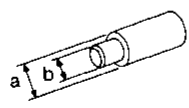
Tool name	Description	
Puller	 NT077	Removing counter bearings, counter drive and OD gears BT
Drift	 NT074	Installing countershaft rear end bearing (FS5W71C-4WD model) a: 40 mm (1.57 in) dia. b: 30 mm (1.18 in) dia.

Replacing Rear Oil Seal — 2WD Model

REMOVAL

1. Remove the propeller shaft. Refer to PD section (“Removal and Installation”, “PROPELLER SHAFT”).
2. Remove rear oil seal using Tool.
 - **Always replace with a new seal once it has been removed.**

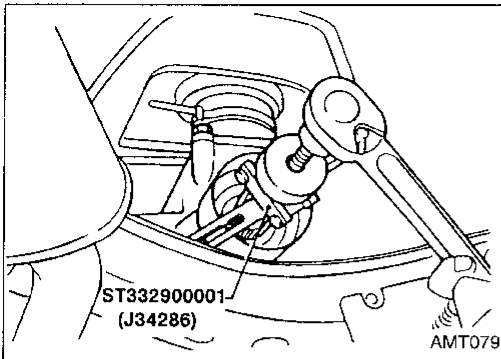

INSTALLATION

1. Install new oil seal until it stops.
 - **Apply multi-purpose grease to seal lip of oil seal before installing.**
2. Install any part removed.

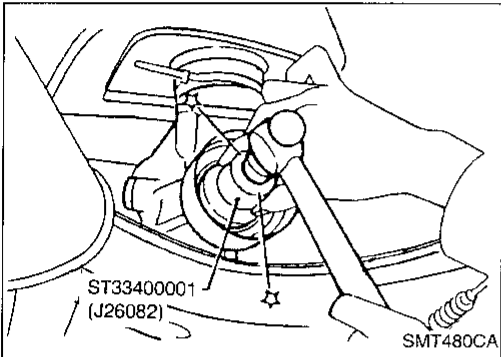

Position Switch Check

- Check continuity.

Switch	Gear position	Continuity
Back-up lamp switch	Reverse	Yes
	Except reverse	No
Neutral position switch	Neutral	Yes
	Except neutral	No

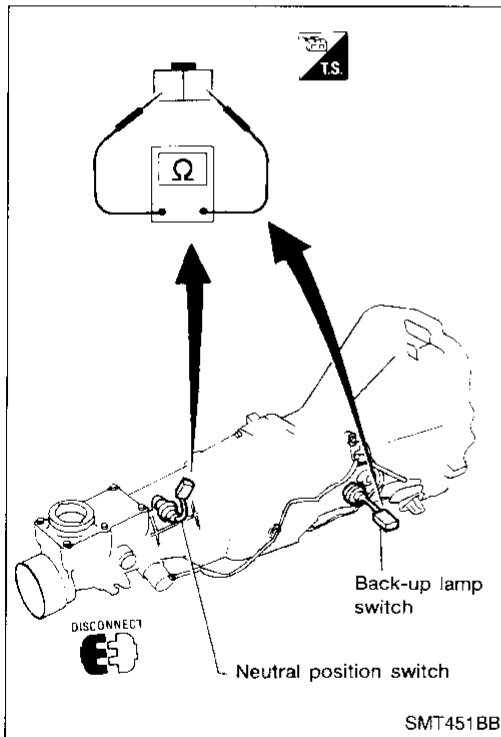

Removal

CAUTION:

Before separating the transmission from the engine, remove the crankshaft position sensor (OBD) from the transmission. Be careful not to damage sensor edge or ring gear teeth.

2WD MODEL

1. Remove battery negative terminal.
 2. Remove crankshaft position sensor (OBD) from transmission upper side.
 3. Remove clutch operating cylinder from transmission.
 4. Remove back-up switch and neutral position switch harness connectors.
 5. Remove starter motor from transmission.
 6. Remove propeller shaft. Refer to PD section ("Removal and Installation", "PROPELLER SHAFT").
- **Insert plug into rear oil seal after removing propeller shaft.**
 - **Be careful not to damage spline, sleeve yoke and rear oil seal when removing propeller shaft.**

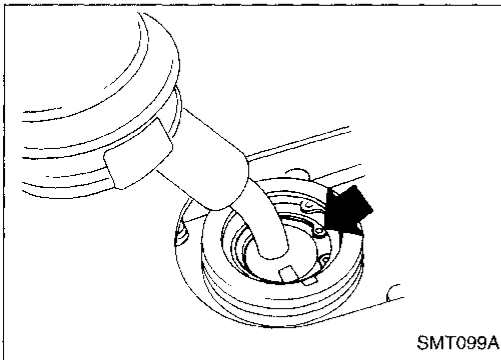

7. Remove control lever.
 8. Support engine by placing a jack under oil pan.
- **Do not place jack under oil pan drain plug.**
9. Separate transmission from engine.

WARNING:

Support manual transmission while removing it.

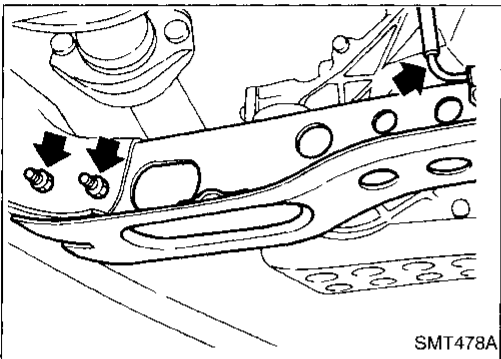

4WD MODEL

1. Remove battery negative terminal.
 2. Remove crankshaft position sensor (OBD) from transmission upper side.
 3. Remove clutch operating cylinder from transmission.
 4. Remove back-up switch and neutral position switch harness connector.
 5. Remove starter motor from transmission.
 6. Remove front and rear propeller shafts. Refer to PD section ("Removal and Installation", "PROPELLER SHAFT").
- **Insert plug into front and rear oil seals of transfer after removing propeller shafts.**
 - **Be careful not to damage splines, sleeve yokes and front and rear oil seals of transfer when removing propeller shafts.**
7. Remove torsion bar springs. Refer to FA section ("Torsion Bar Spring", "FRONT SUSPENSION"). Then remove second crossmember.

REMOVAL AND INSTALLATION

Removal (Cont'd)

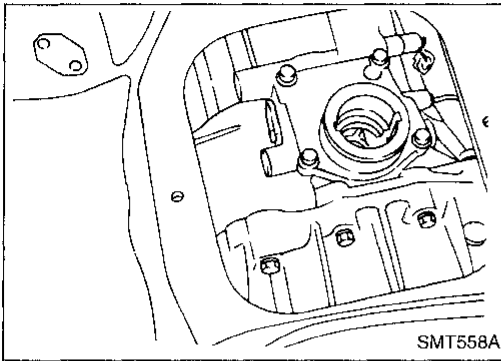

8. Remove transmission and transfer control levers.
9. Support engine by placing a jack under oil pan.
- **Do not place jack under oil pan drain plug.**
10. Separate transmission with transfer from engine.

WARNING:

Support manual transmission with transfer while removing it.

Installation

1. Apply sealant to areas shown below: — 4WD model

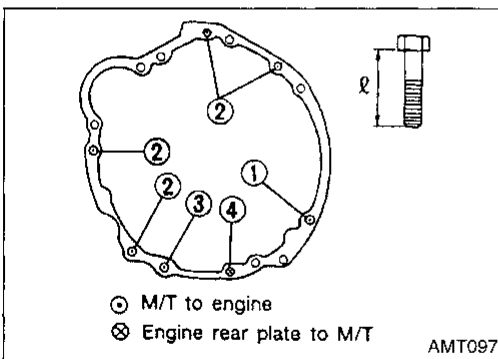
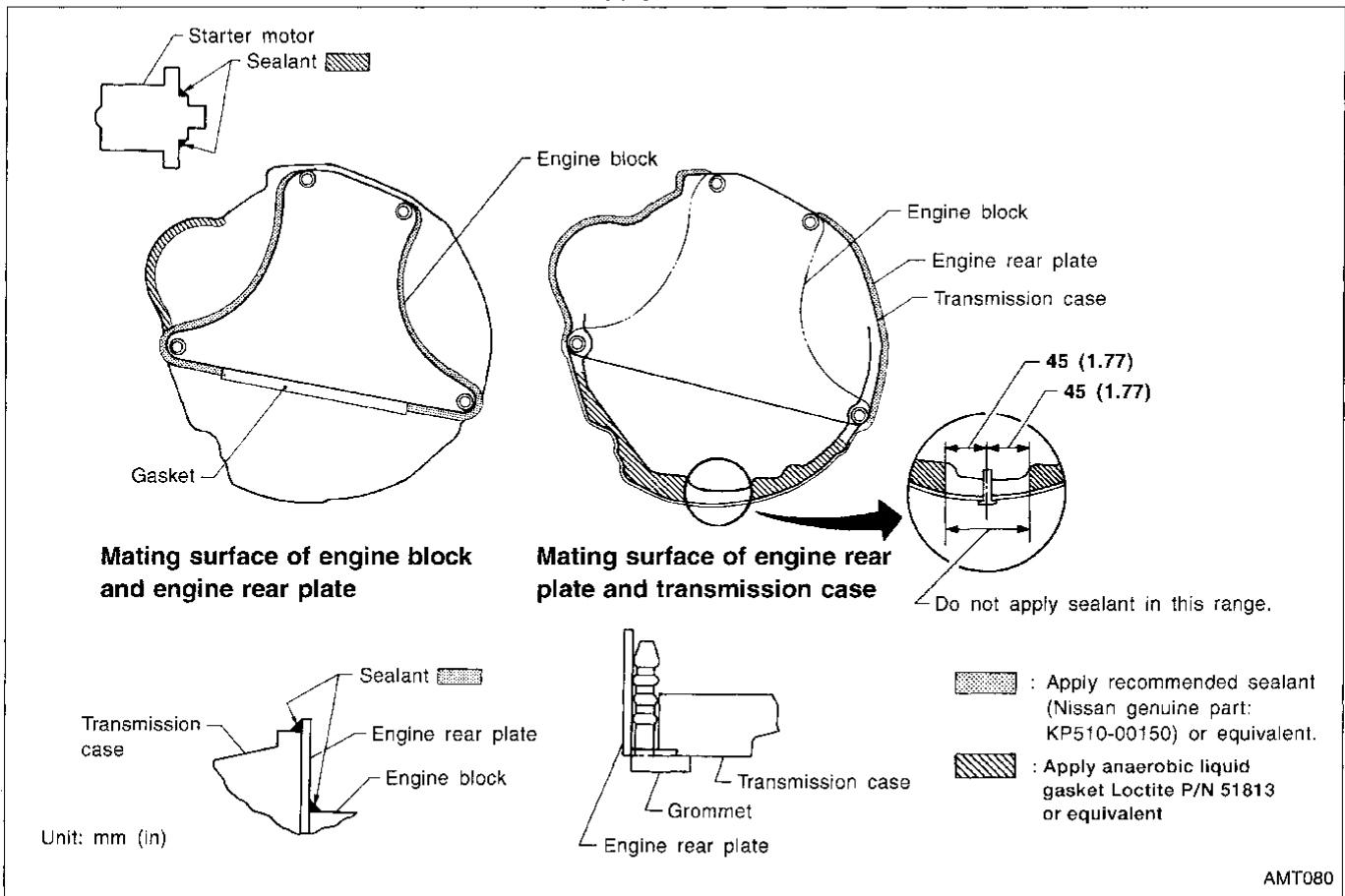

2. Tighten bolts securing transmission.

Bolt No.	Tightening torque N·m (kg·m, ft·lb)	ℓ mm (in)
①	39 - 49 (4.0 - 5.0, 29 - 36)	65 (2.56)
②	39 - 49 (4.0 - 5.0, 29 - 36)	58 (2.28)
③*	16 - 22 (1.6 - 2.2, 12 - 16)	25 (0.98)
④	16 - 22 (1.6 - 2.2, 12 - 16)	16 (0.63)

*: With nut

3. Tighten clutch operating cylinder to the specified torque. Refer to CL section ("CLUTCH SYSTEM").

MAJOR OVERHAUL

Case Components

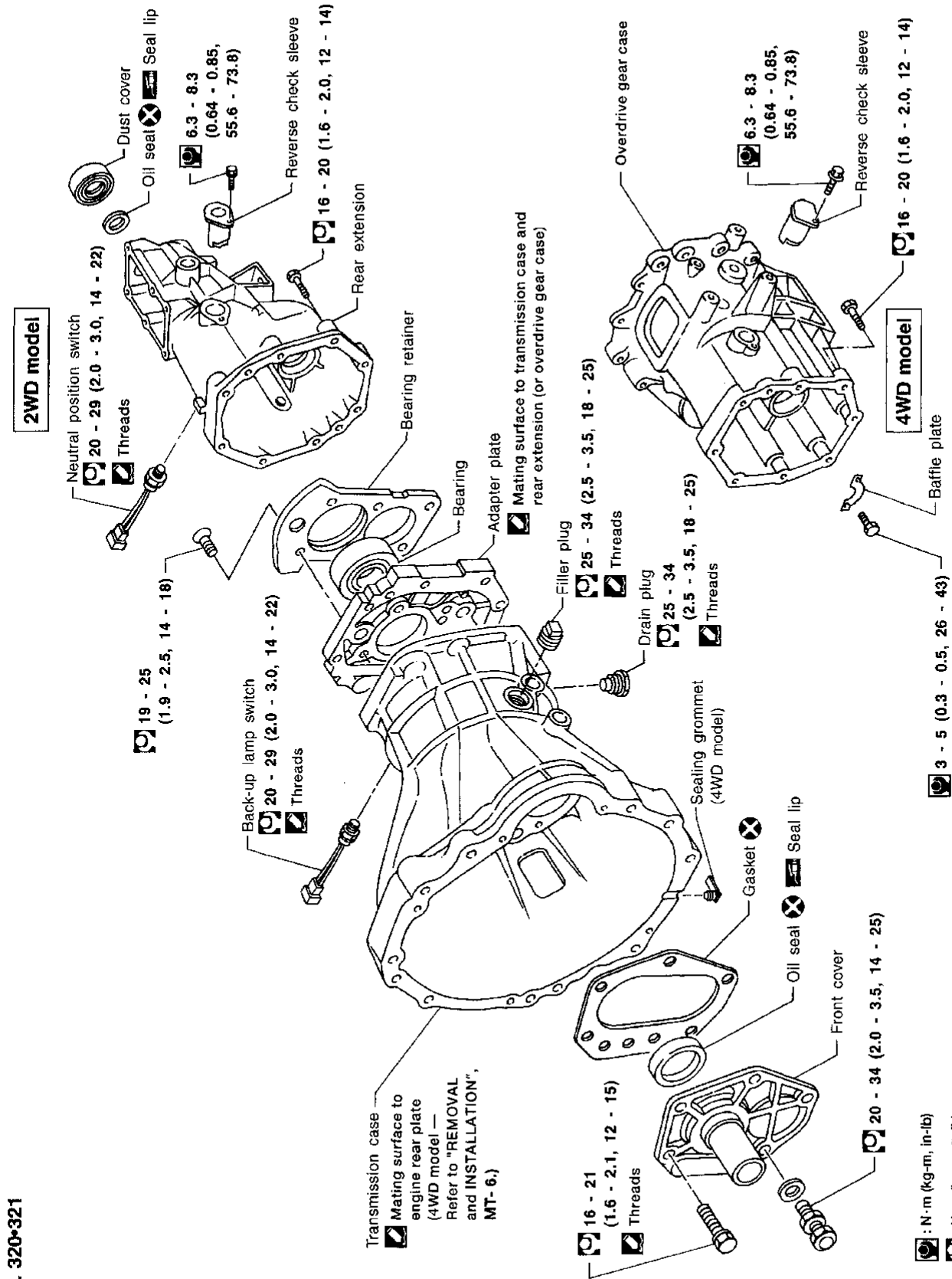

SEC. 320-321

MT-7

AMT108

GI
MA
EM
LC
EC
FE
CL
MT
AT
TF
PD
FA
RA
BR
ST
RS
BT
HA
EL
IDX

MAJOR OVERHAUL

Gear Components — 2WD Model

SEC. 322

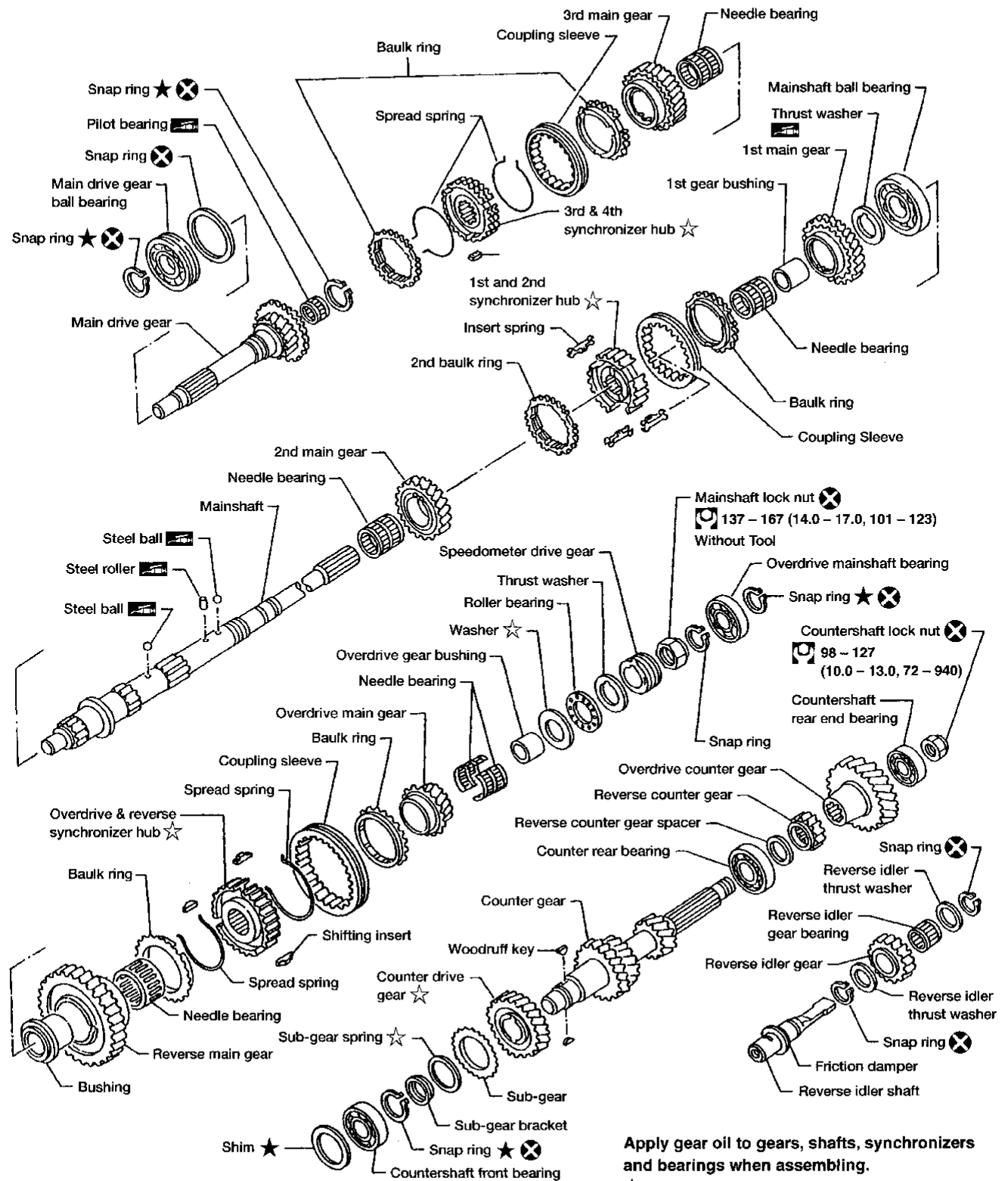

Apply gear oil to gears, shafts, synchronizers and bearings when assembling.

- ★ : Select proper thickness
- ☆ : Pay attention to its direction
- ⊗ : N · m (kg-m, ft-lb)
- ☒ : Should be lubricated with grease

AMT105

MAJOR OVERHAUL

Gear Components — 4WD Model

SEC. 322

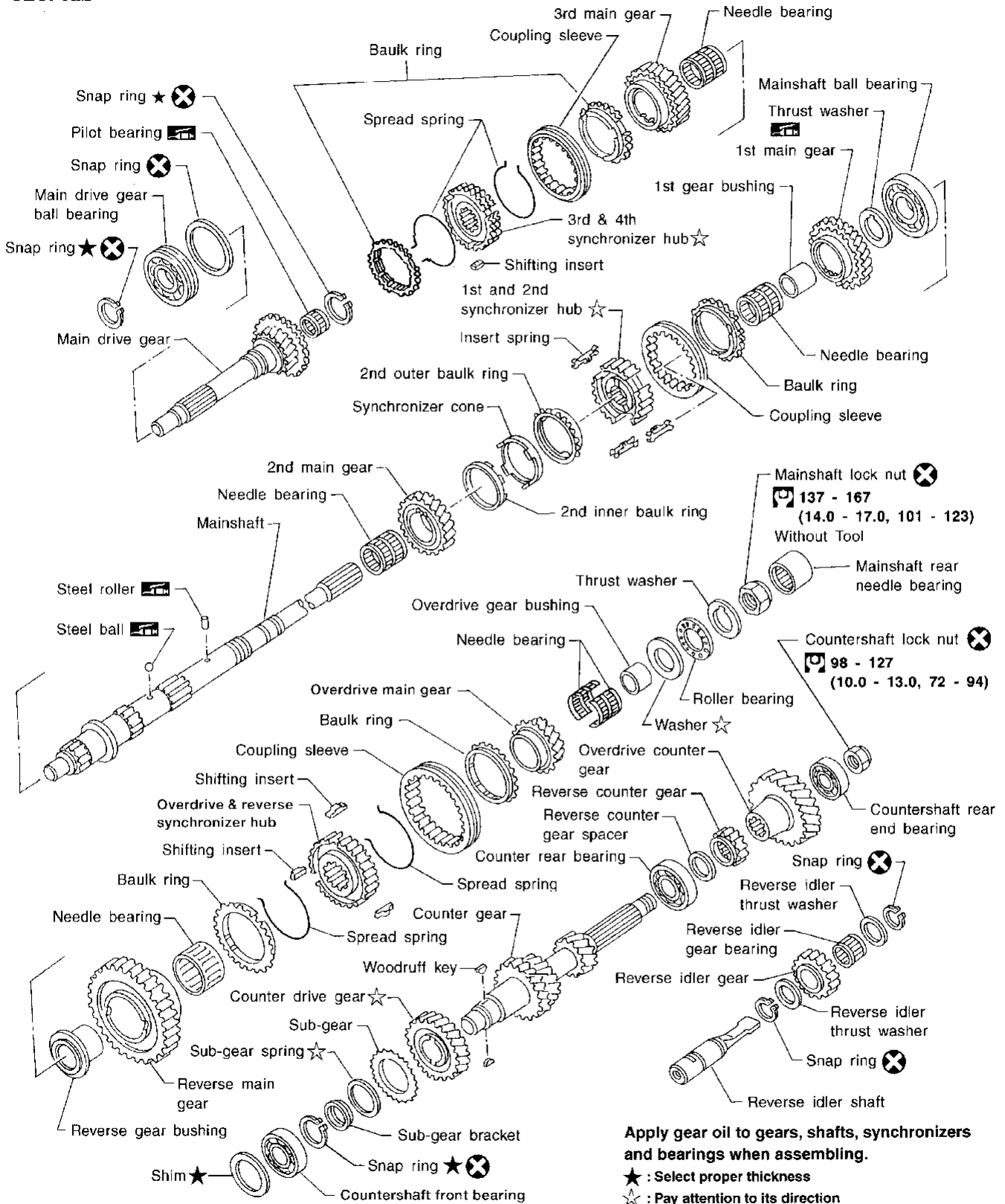

Apply gear oil to gears, shafts, synchronizers and bearings when assembling.

- ★ : Select proper thickness
- ☆ : Pay attention to its direction
- ⊗ : N·m (kg-m, ft-lb)
- ☑ : Should be lubricated with grease

GI
MA
EM
LC
EC
FE
CL
MT
AT
TF
PD
FA
RA
BR
ST
RS
BT
HA
EL
IDX

Shift Control Components

CAUTION:

To avoid damage when replacing shift knob, remove control lever with knob, as assembled.

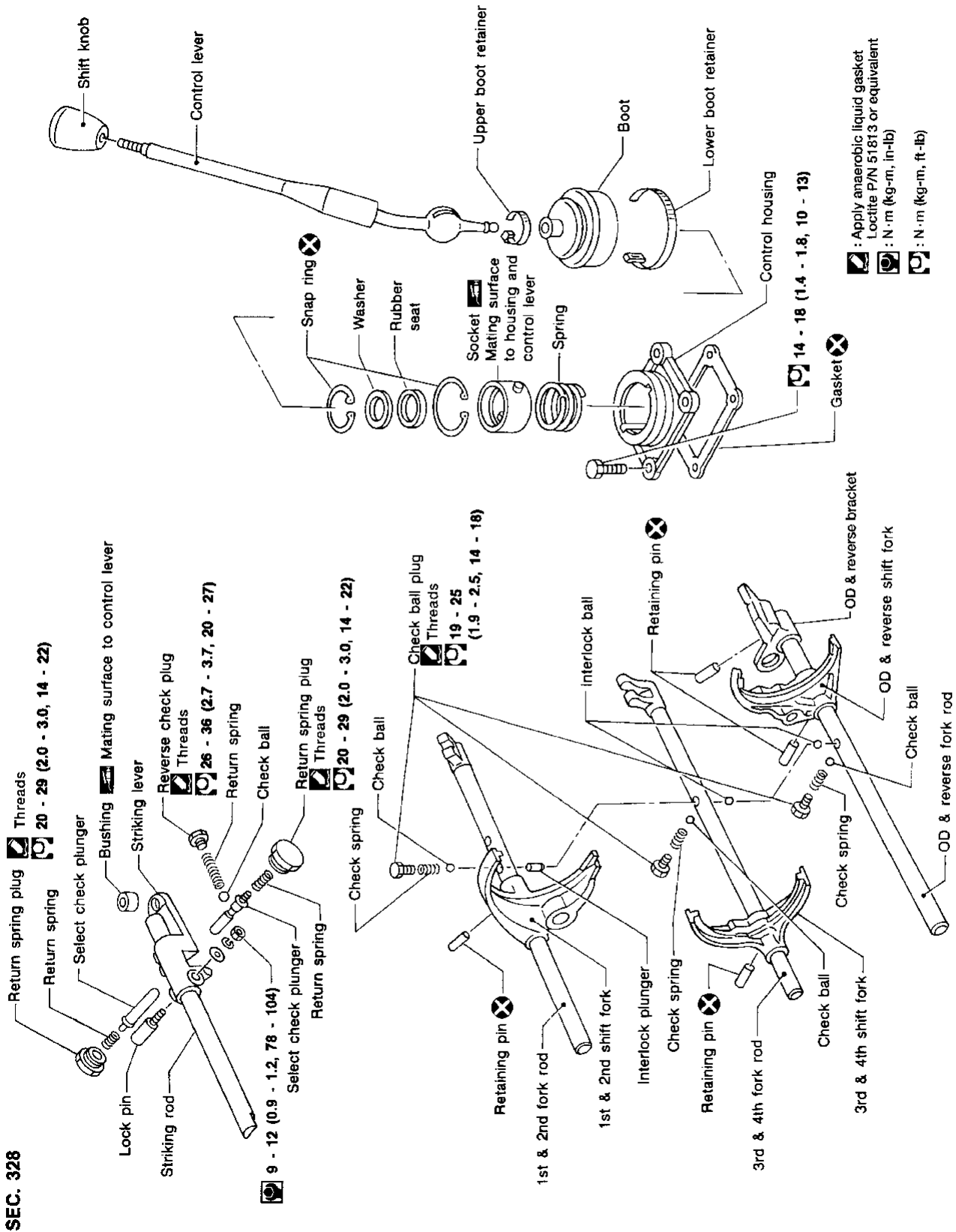

: Apply anaerobic liquid gasket
 Loctite P/N 51813 or equivalent
 : N · m (kg-m, in-lb)
 : N · m (kg-m, ft-lb)

SEC. 328

DISASSEMBLY

GI

MA

EM

LC

EC

FE

GL

MT

AT

TF

PD

FA

RA

BR

ST

RS

BT

HA

EL

IDX

Case Components

1. Remove rear extension.
 - a. Remove control housing, check ball, return spring plugs, select check plungers and return springs. Also remove reverse check plug, check spring and check ball.
- **Be careful not to lose check balls.**

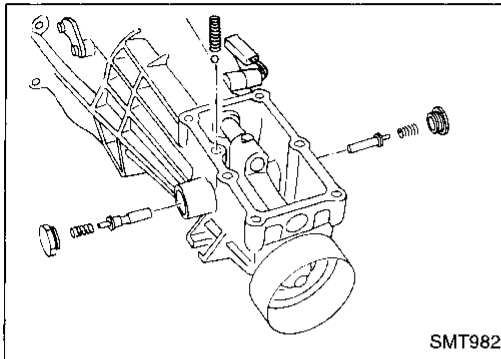

- b. Drive out striking lever retaining pin.
- c. Remove striking lever from striking rod.
- d. Remove rear extension by lightly tapping on it.

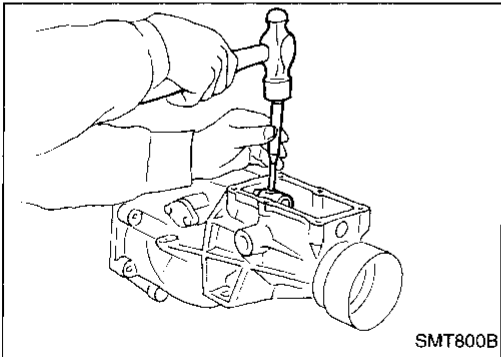

2. Remove front cover, gasket, countershaft front bearing shim and main drive gear ball bearing snap ring.
3. Separate transmission case from adapter plate by lightly tapping on it.

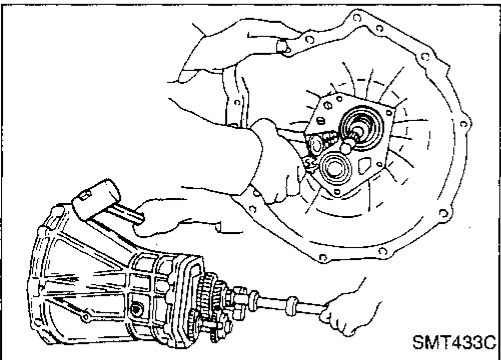

4. Remove oil seal from front cover.
- **Be careful not to damage mating surface of front cover.**

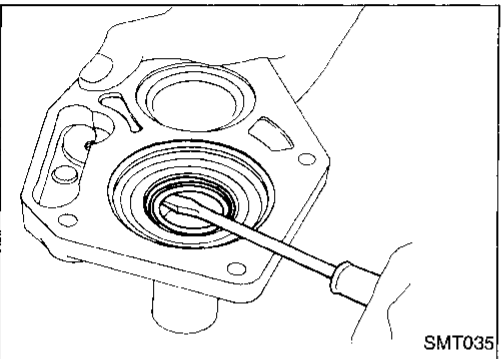

Shift Control Components

1. Set up Tool on adapter plate.
2. Remove striking rod from adapter plate.
3. Remove check ball plugs, check springs, and check balls.

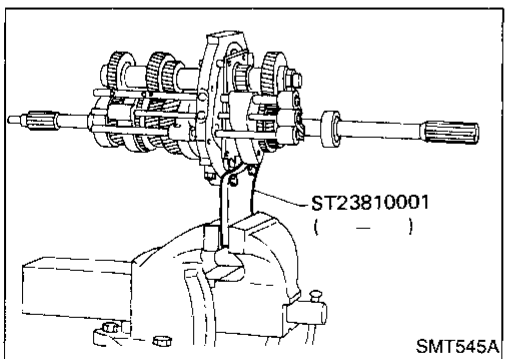

DISASSEMBLY

Shift Control Components (Cont'd)

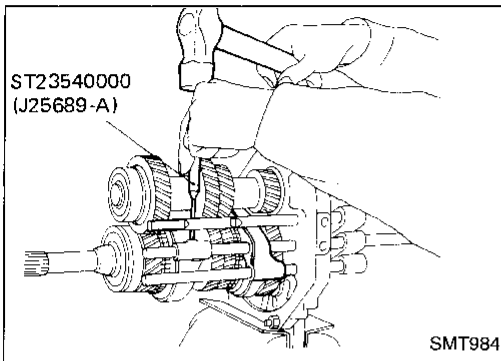

4. Drive out retaining pins. Then drive out fork rods and remove interlock balls.

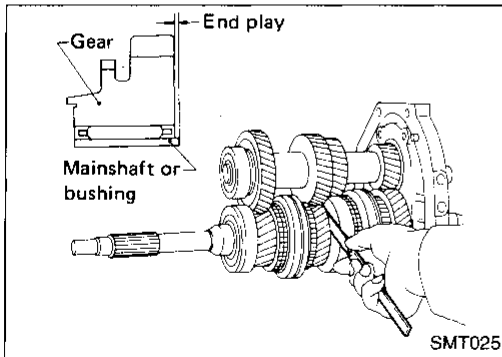

Gear Components

1. Before disassembly, measure the end play of each gear.
 - If end play is not within the specified limit, disassemble and inspect the parts.
 - Replace any part which is worn or damaged.

Gear end play:

Refer to SDS, MT-28.

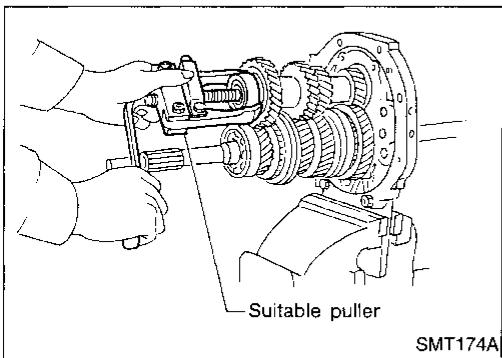

2. Mesh 2nd and reverse gear, then remove countershaft front bearing using a suitable puller.
3. Remove snap ring, then remove sub-gear bracket, sub-gear spring and sub-gear.

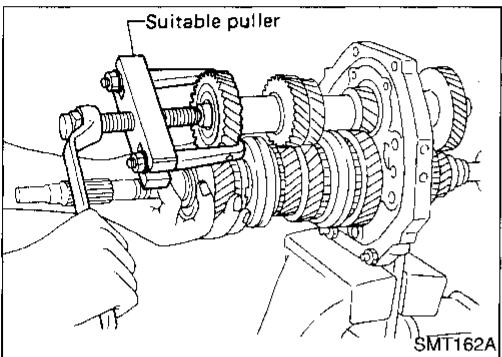

4. Remove counter drive gear together with main drive gear assembly using a suitable puller.
 - **When removing main drive gear assembly, be careful not to drop pilot bearing or baulk ring.**
5. Remove snap ring, then remove 3rd & 4th synchronizer assembly and 3rd main gear.

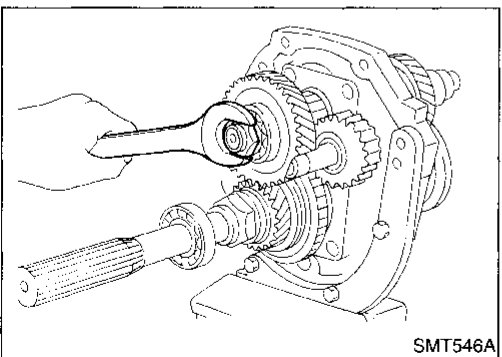

6. Disassemble parts at rear of adapter plate as follows:
 - a. Release staking on both countershaft and mainshaft nuts, then loosen both nuts.

Mainshaft nut: Left-hand thread

DISASSEMBLY

Gear Components (Cont'd)

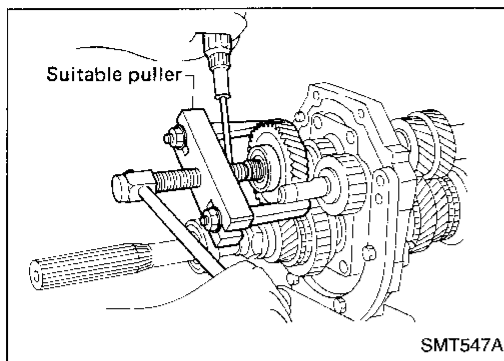

- b. Remove overdrive counter gear together with countershaft rear end bearing using a suitable puller.
- c. Remove reverse counter gear and spacer.
- d. Remove snap rings from reverse idler shaft, then remove reverse idler gear, thrust washers and reverse idler gear bearing.

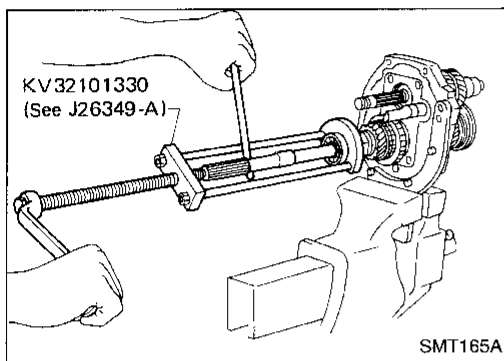

- e. Remove snap ring and pull out overdrive mainshaft bearing, then remove snap ring. (2WD model)
- f. Remove mainshaft nut.
- g. Remove speedometer drive gear and steel ball. (2WD model)
- h. Remove thrust washer, steel roller, roller bearing and washer.
- i. Remove overdrive main gear, needle bearing and baulk ring (overdrive).
- j. Remove counter gear by tapping on rear end of counter gear.
- k. Press out overdrive gear bushing and overdrive & reverse synchronizer assembly.
- l. Remove reverse main gear and needle bearing.
- m. Press out reverse gear bushing.

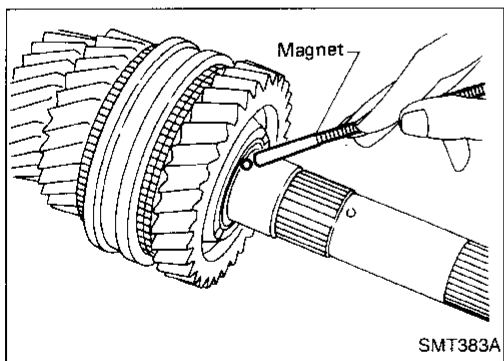
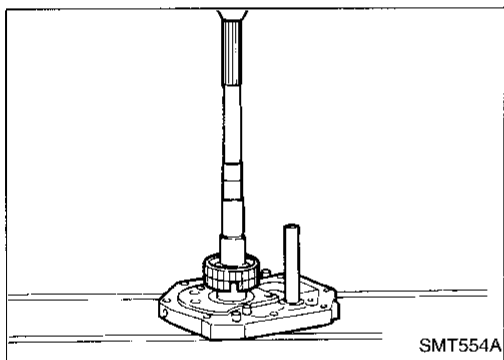

7. Remove thrust washer, steel ball, 1st main gear and needle bearing.
 - **Be careful not to lose steel ball.**

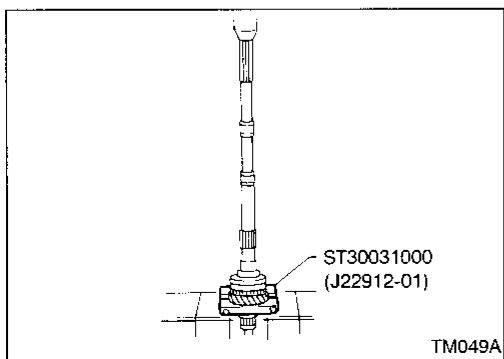

8. Press out 1st gear bushing together with 2nd main gear using Tool. Remove 2nd gear needle bearing.

GI
MA
EM
LC
EC
FE
CL
MT
AT
TF
PD
FA
RA
BR
ST
RS
BT
HA
EL
IDX

DISASSEMBLY

Gear Components (Cont'd)

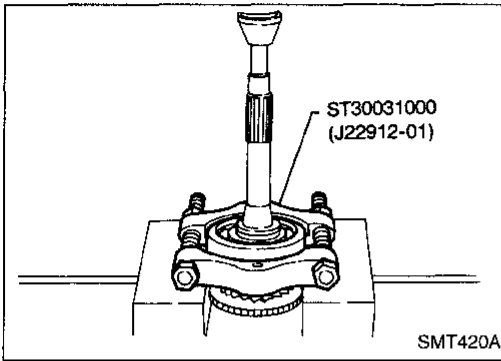

9. Remove main drive gear ball bearing.
 - a. Remove snap ring.
 - b. Remove main drive gear ball bearing.

Shift Control Components

- Check contact and sliding surfaces of fork rods for wear, scratches, projections and other damage.

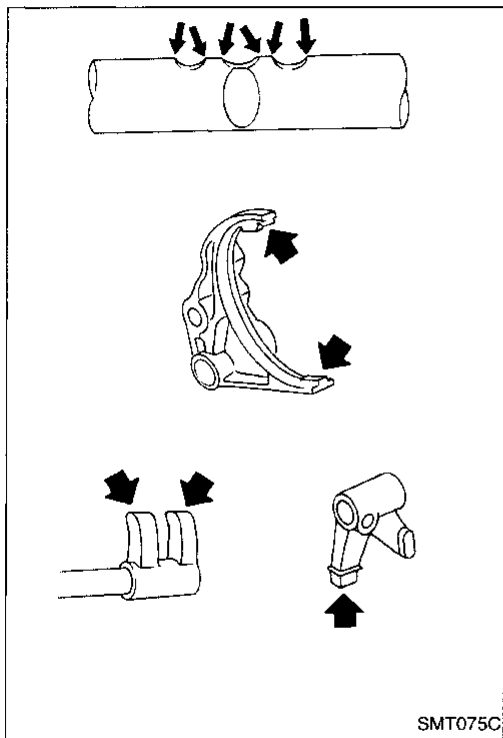

Gear Components

GEARS AND SHAFTS

- Check shafts for cracks, wear and bending.
- Check gears for excessive wear, chips and cracks.

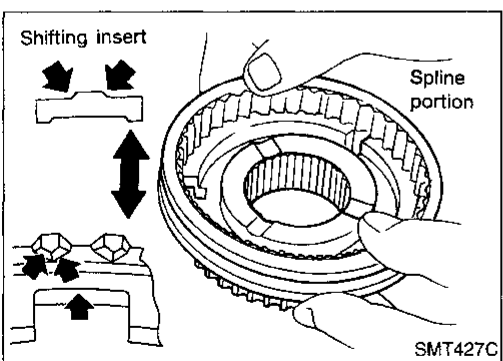
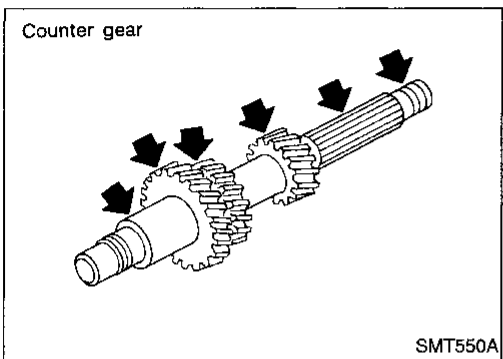
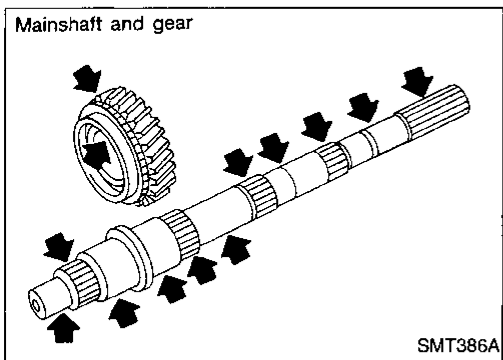

SYNCHRONIZERS

- Check spline portion of coupling sleeves, synchronizer hubs and gears for wear, chips and cracks.
- Check baulk rings for cracks and deformation.
- Check shifting inserts for wear and deformation.
- Check insert spread springs for deformation.

GI

MA

EM

LC

EC

FE

CL

MT

AT

TF

PD

FA

RA

BR

ST

RS

BT

HA

EL

IDX

INSPECTION

Gear Components (Cont'd)

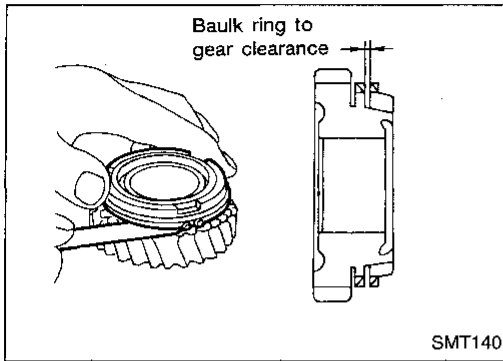

- Measure baulk ring wear.
 - a. Measure clearance between baulk ring and gear.

Clearance between baulk ring and gear:
Refer to SDS, MT-28.
- If the clearance is less than the wear limit, replace baulk ring.

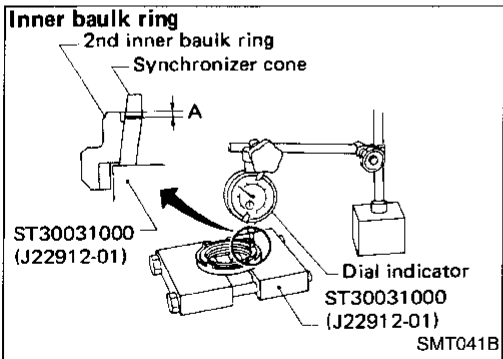

- Measure 2nd baulk ring wear—4WD model.
 - a. Place baulk rings in position on synchronizer cone.
 - b. While holding baulk rings against synchronizer cone as far as possible, measure dimensions "A" and "B".

Standard:

Inner "A": 0.7 - 0.9 mm (0.028 - 0.035 in)

Outer "B": 0.6 - 1.1 mm (0.024 - 0.043 in)

Wear limit:

0.2 mm (0.008 in)

- c. If dimension "A" or "B" is less than the wear limit, replace baulk ring.

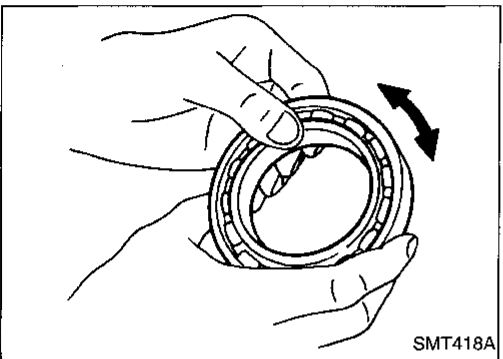
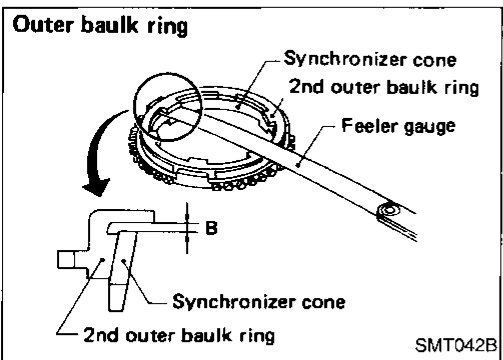

BEARINGS

- Make sure all bearings roll freely and are free from noise, cracks, pitting or wear.

Gear Components

GI

MA

EM

LC

EC

FE

CL

MT

AMT085

Mainshaft ball bearing in adapter plate

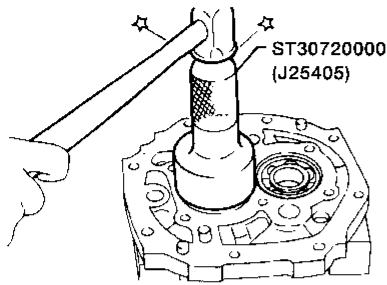

Counter rear bearing in adapter plate

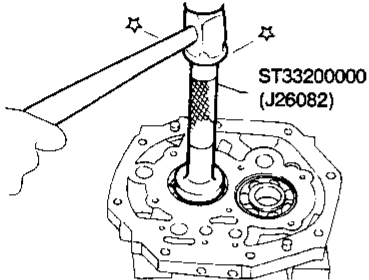

Countershaft rear end bearing in overdrive gear case (4WD model)

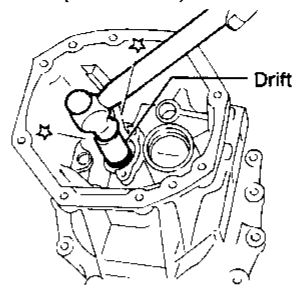

Install until flush with front surface of overdrive gear case.

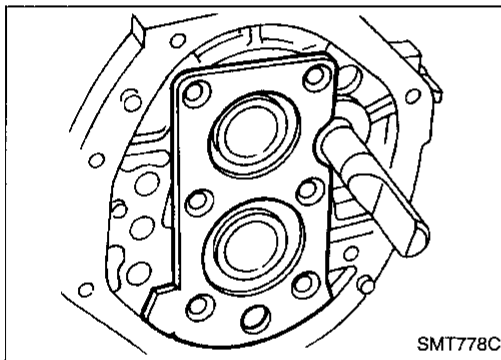

1. Install bearings into case components.
2. Assemble adapter plate parts.
 - Install oil gutter on adapter plate and expand on rear side.
 - Install bearing retainer.
- a. Insert reverse idler shaft, then install bearing retainer.

AT

TF

PD

FA

RA

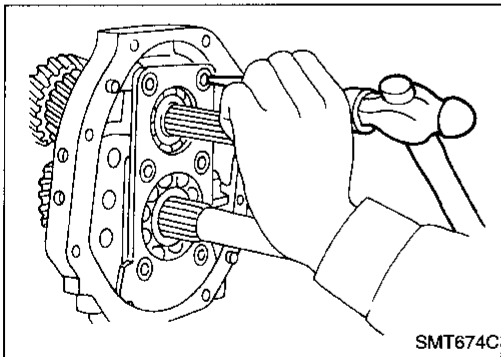

- b. Tighten each screw, then stake each one at two points.

BR

ST

RS

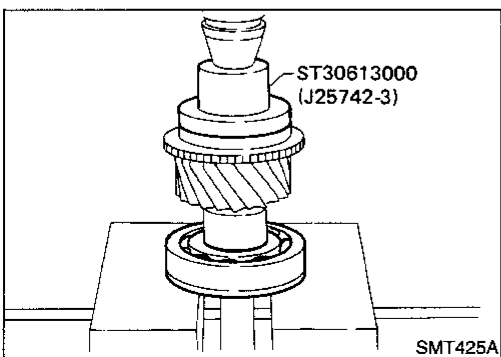

3. Install main drive gear ball bearing.
 - a. Press main drive gear ball bearing.

BT

HA

EL

IDX

ASSEMBLY

Gear Components (Cont'd)

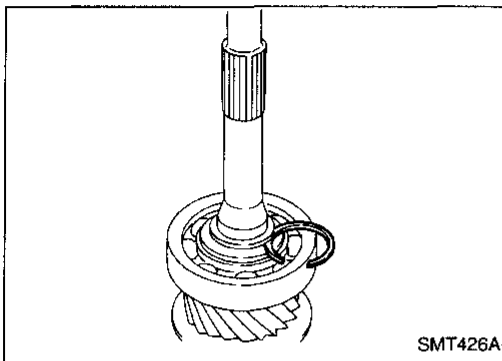

- b. Select and install proper main drive gear snap ring to achieve proper clearance of groove.

Allowable clearance of groove:

0 - 0.13 mm (0 - 0.0051 in)

Main drive gear snap ring:

Refer to SDS, MT-28.

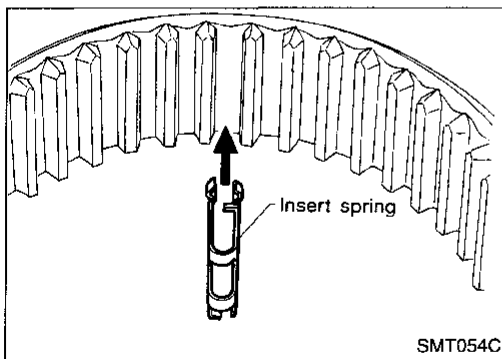

4. Assemble synchronizers.

- 1st and 2nd (2WD model) synchronizer

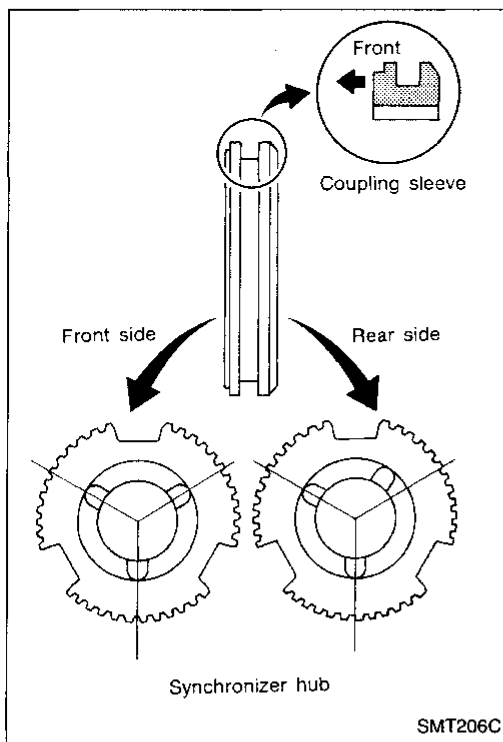

- Check coupling sleeve and synchronizer hub orientation.

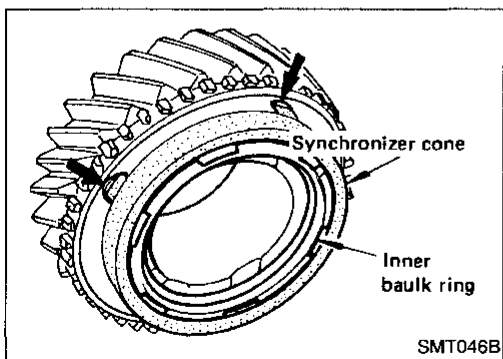

- 2nd double baulk ring type synchronizer (4WD model)

ASSEMBLY

Gear Components (Cont'd)

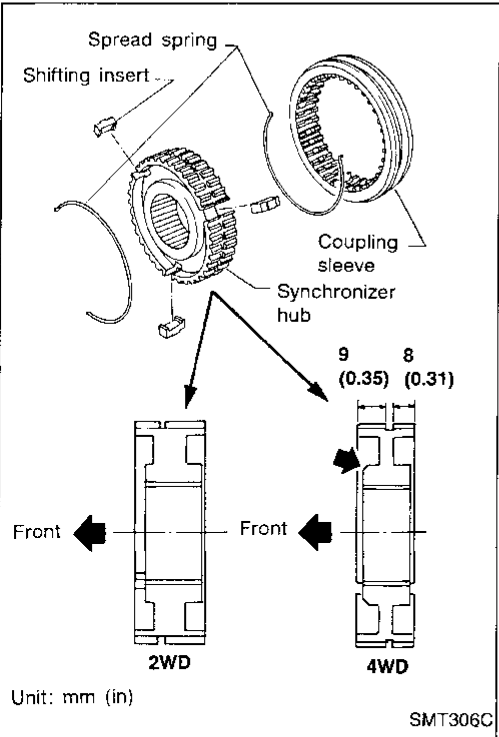
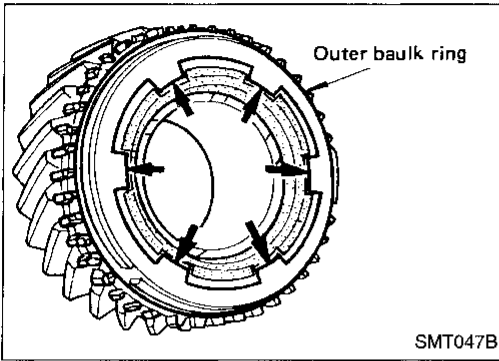

- 3rd & 4th synchronizer
- **The three synchronizer gutters should be at the rear.**

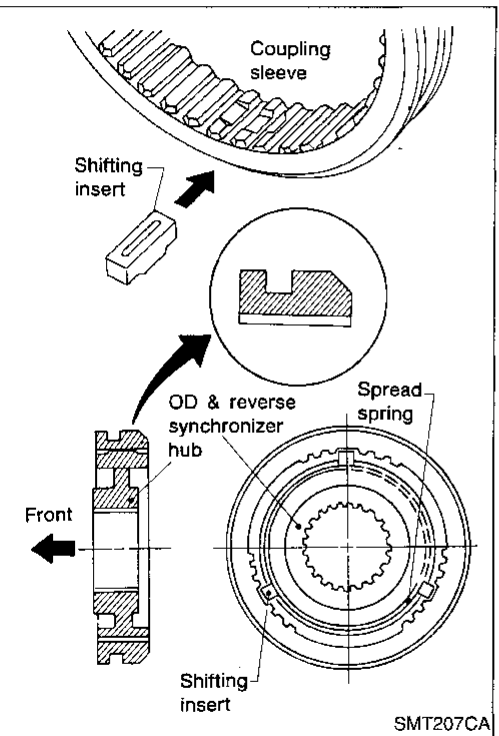

- Overdrive & reverse synchronizer

GI
MA
EM
LC
EC
FE
CL
MT
AT
TF
PD
FA
RA
BR
ST
RS
BT
HA
EL
IDX

ASSEMBLY

Gear Components (Cont'd)

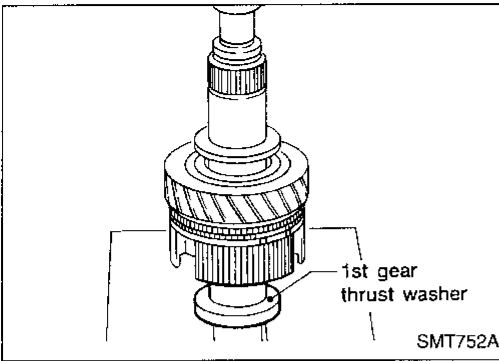

5. Assemble front side components to mainshaft.
 - a. Install 2nd main gear, needle bearing and 1st & 2nd synchronizer assembly, then press 1st gear bushing on mainshaft.
 - b. Install 1st main gear.

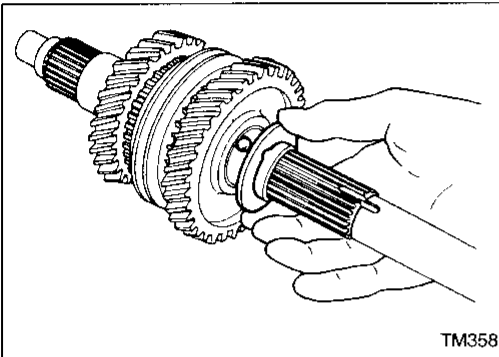

- c. Install steel ball and 1st gear washer.
 - **Before installation, apply multi-purpose grease to steel ball and to both sides of the 1st gear washer.**

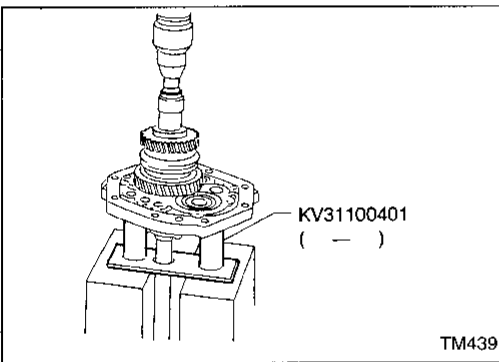

6. Install mainshaft and counter gear on adapter plate and main drive gear on mainshaft as follows:
 - a. Press mainshaft assembly into adapter plate using Tool.

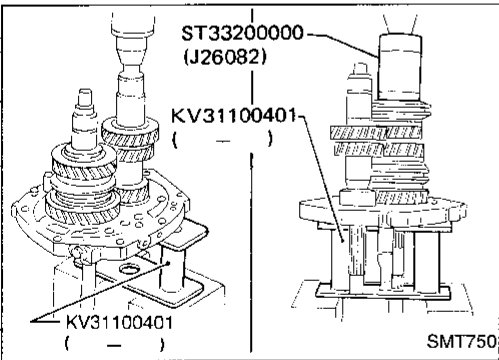

- b. Press counter gear into adapter plate using Tool.
- c. Install 3rd main gear and needle bearing, then press 3rd & 4th synchronizer assembly onto mainshaft.
 - **Pay attention to the direction of 3rd & 4th synchronizer.**

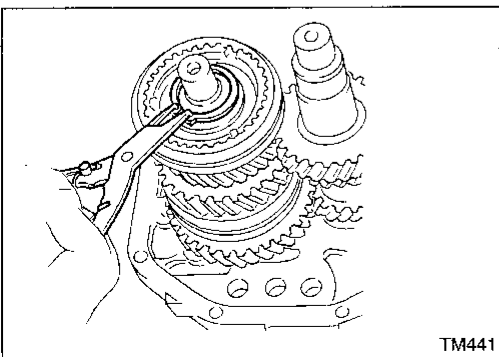

- d. Install front mainshaft snap ring.

Select proper front mainshaft snap ring to achieve proper clearance of groove.

Allowable clearance of groove:
0 - 0.18 mm (0 - 0.0071 in)

Mainshaft front snap ring:
Refer to SDS, MT-28.
- e. Apply gear oil to mainshaft pilot bearing and install it on mainshaft.

ASSEMBLY

Gear Components (Cont'd)

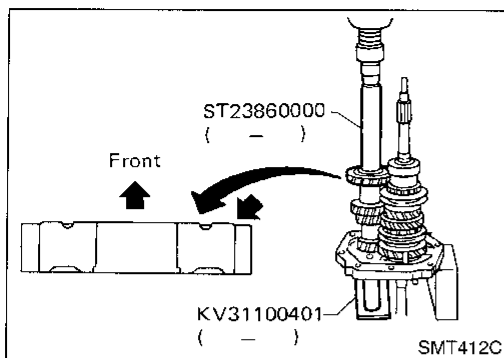

f. Press counter drive gear together with main drive gear using Tool.

- Pay attention to the direction of counter drive gear.

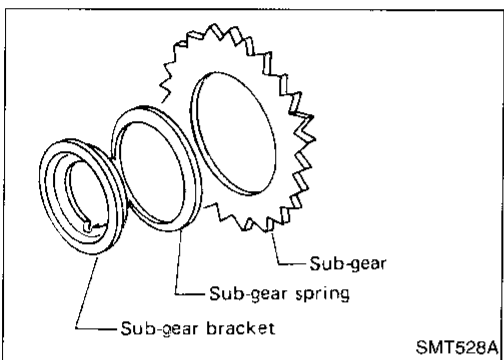

g. Install sub-gear components.

- (1) Install sub-gear and sub-gear bracket on counter drive gear, then select proper snap ring to achieve proper clearance of groove.

Allowable clearance of groove:

0 - 0.18 mm (0 - 0.0071 in)

Counter drive gear snap ring:

Refer to SDS, MT-28.

- (2) Remove snap ring, sub-gear bracket and sub-gear from counter gear.
- (3) Reinstall sub-gear, sub-gear spring and sub-gear bracket.

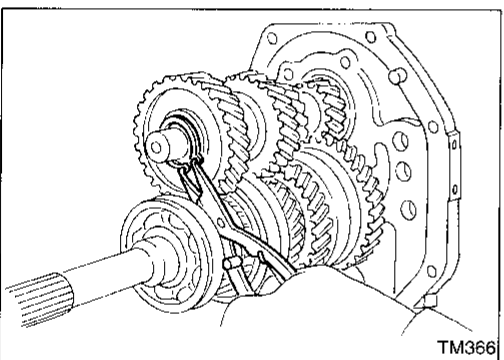

h. Install selected counter drive gear snap ring.

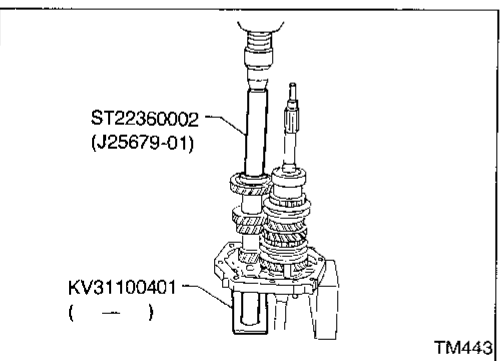

i. Press countershaft front bearing onto counter gear using Tool.

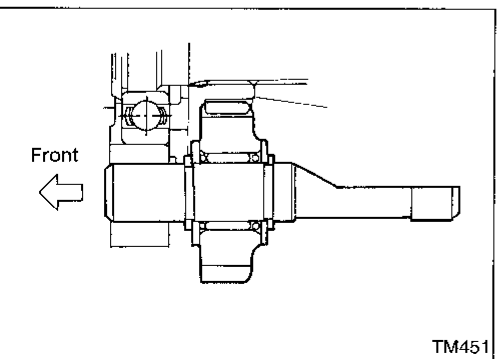

7. Install rear side components on mainshaft and counter gear as follows:

- a. Install reverse idler gear to reverse idler shaft along with spacers, snap rings and reverse idler gear bearing.

ASSEMBLY

Gear Components (Cont'd)

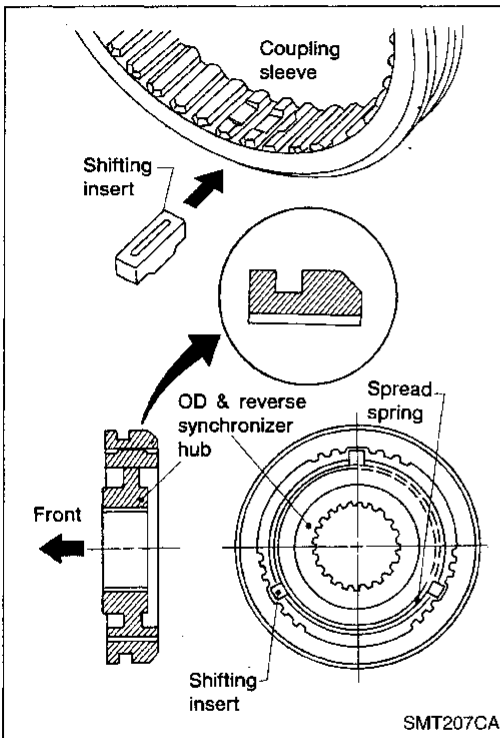

- b. Install bushing, reverse main gear and overdrive & reverse synchronizer to mainshaft.
- **Pay attention to the direction of synchronizer hub.**

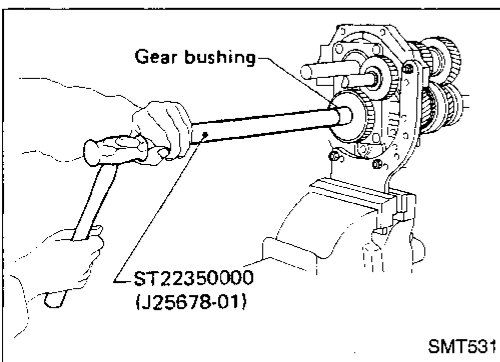

- c. Install overdrive gear bushing to mainshaft using Tool.
 - d. Install overdrive main gear and needle bearing to mainshaft.
 - e. Install spacer, reverse counter gear and overdrive counter gear to countershaft.
- **OD main gear and OD counter gear should be handled as a matched set.**
 - f. Install washer, roller bearing, steel roller and thrust washer.
 - g. Tighten mainshaft lock nut temporarily.
 - **Always use new lock nut.**

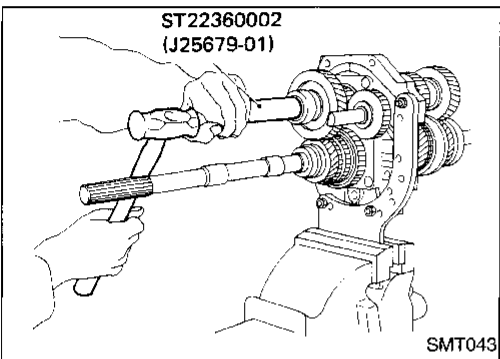

- h. Install countershaft rear end bearing using Tool.

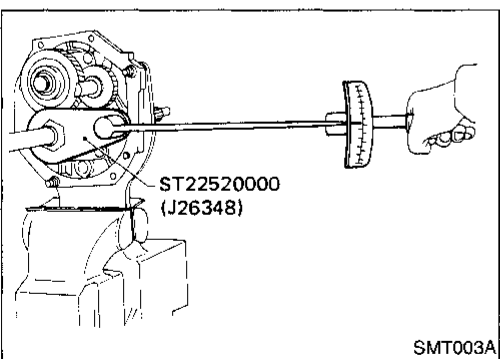

8. Mesh 2nd and reverse gears, then tighten mainshaft lock nut using Tool.
- **Always use new lock nut.**
Mainshaft lock nut:
: 137 - 167 N·m (14.0 - 17.0 kg·m, 101 - 123 ft·lb)

ASSEMBLY

Gear Components (Cont'd)

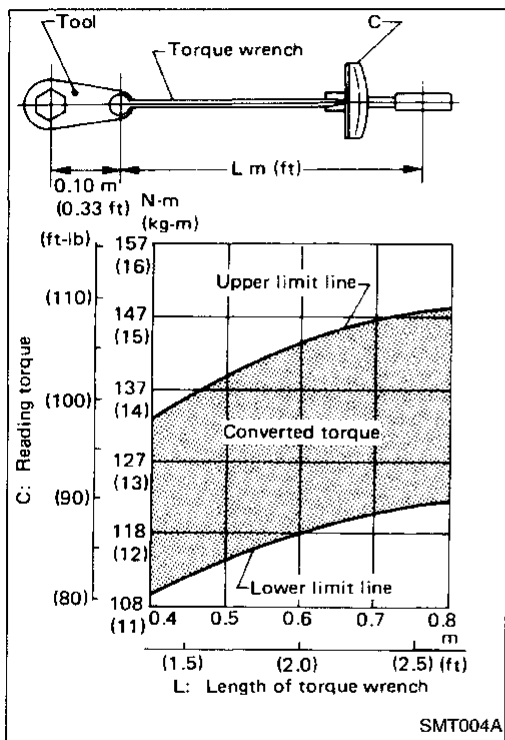

- Use the chart shown at left to determine the proper reading torque. (Length of torque wrench vs. setting or reading torque)
9. Tighten countershaft lock nut.
- **Always use new lock nut.**
Countershaft lock nut:
: 98 - 127 N-m (10.0 - 13.0 kg-m, 72 - 94 ft-lb)

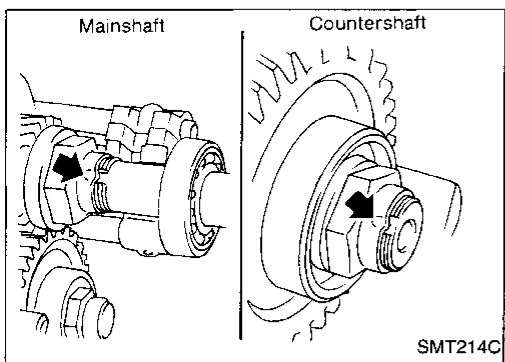

10. Stake mainshaft lock nut and countershaft lock nut using a punch.
11. Measure gear end play. Refer to "Gear Components", "DISASSEMBLY", MT-12.

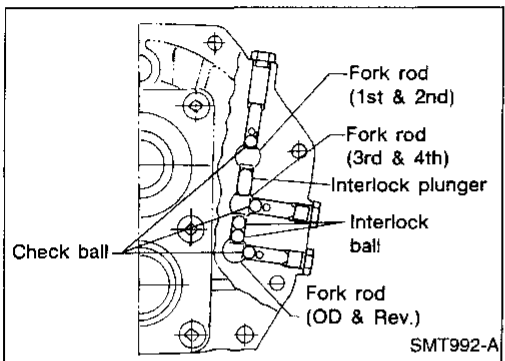

Shift Control Components

1. Install fork rods, interlock plunger, interlock balls and check balls.
2. Install 1st & 2nd shift fork, then drive in retaining pin.

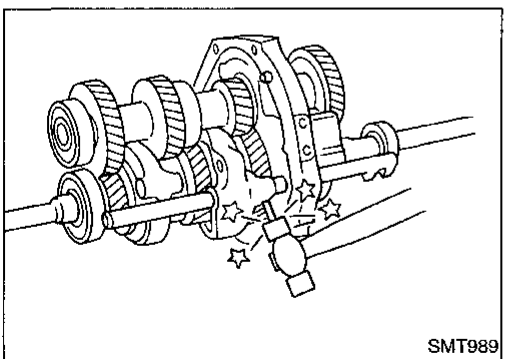

GI
MA
EM
LC
EC
FE
CL
MT
AT
TF
PD
FA
RA
BR
ST
RS
BT
HA
EL
IDX

ASSEMBLY

Shift Control Components (Cont'd)

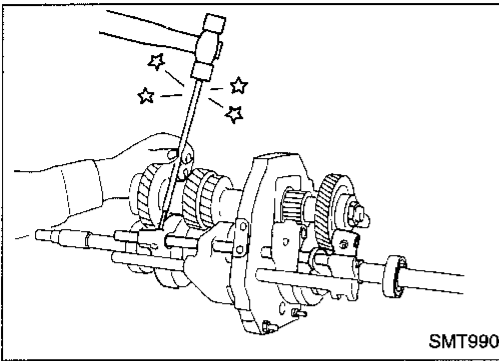

3. Install 3rd & 4th shift fork, then drive in retaining pin.

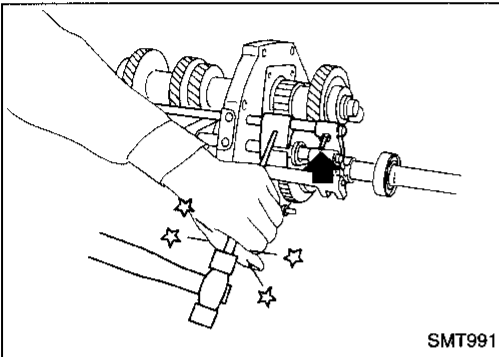

4. Install overdrive & reverse shift fork, then drive in retaining pin.

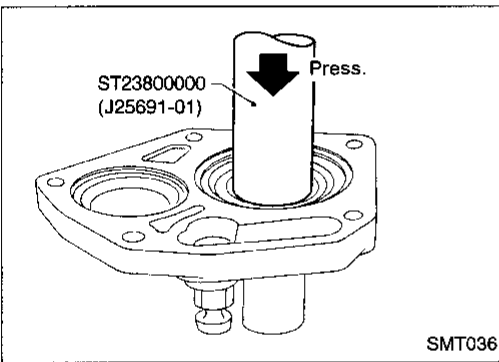

Case Components

1. Install front cover oil seal using Tool.
 - Apply multi-purpose grease to seal lip.

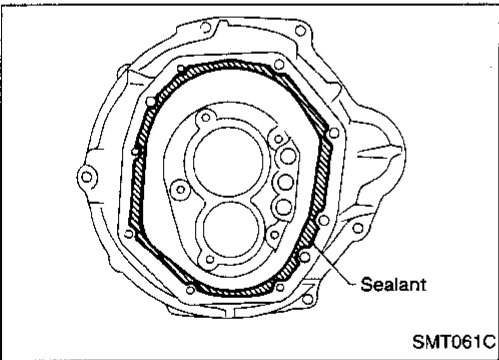

2. Apply sealant to mating surface of transmission case as shown at left.
 - Use anaerobic liquid gasket Loctite P/N 51813 or equivalent.

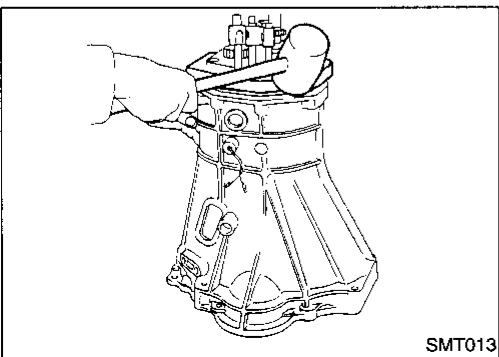

3. Slide gear assembly onto adapter plate by lightly tapping it using a soft hammer.

ASSEMBLY

Case Components (Cont'd)

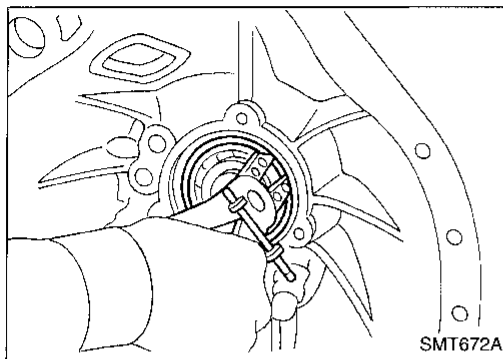

4. Install main drive gear ball bearing snap ring.

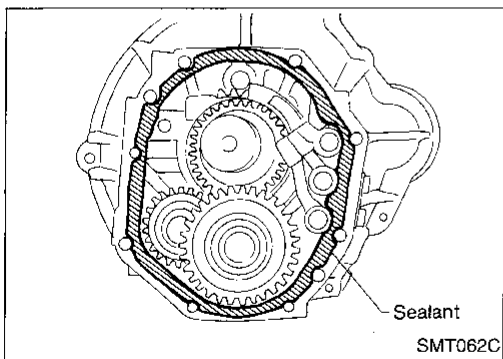

5. Apply sealant to mating surface of adapter plate as shown at left.

- Use anaerobic liquid gasket Loctite P/N 51813 or equivalent.

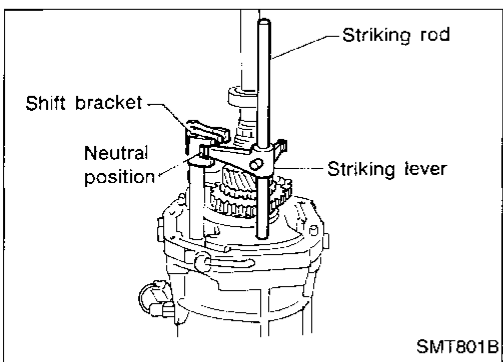

6. Place shift forks in neutral position.

7. Install striking lever and rod onto adapter plate and align striking lever with shift brackets.

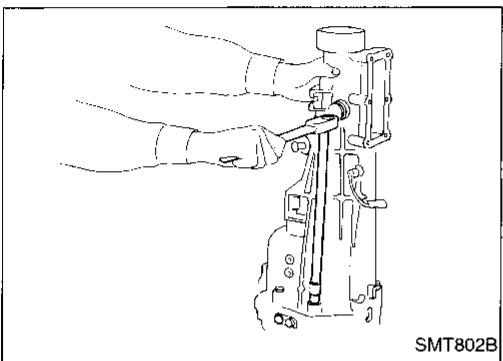

8. Install rear extension.

9. Fit main drive bearing snap ring.

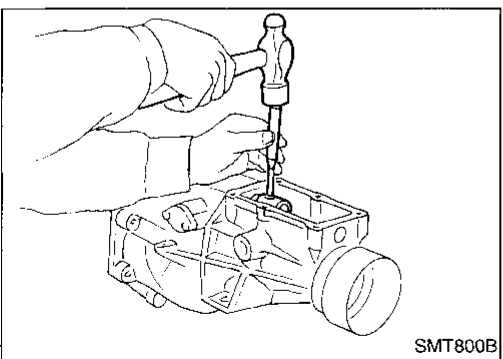

10. Install striking rod lock pin.

GI

MA

EM

LC

EC

FE

CL

MT

AT

TF

PD

FA

RA

BR

ST

RS

BT

HA

EL

IDX

ASSEMBLY

Case Components (Cont'd)

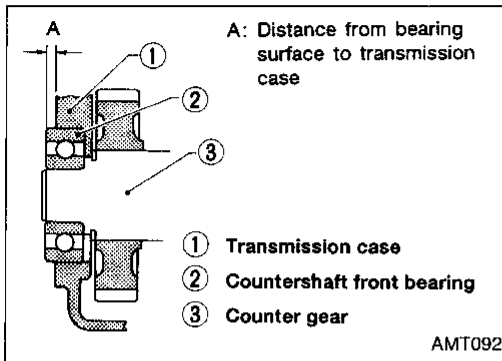

11. Select countershaft front bearing shim.

Countershaft front bearing shim:
Refer to SDS, MT-29.

12. Install gasket and front cover.

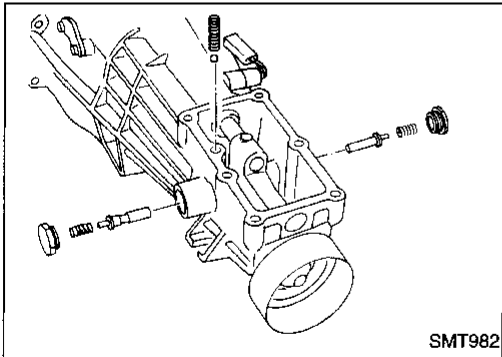

13. Install return spring plugs, check ball, return springs and select check plungers.

14. Install control housing and gasket.

SERVICE DATA AND SPECIFICATIONS (SDS)

General Specifications

Applied model	2WD	4WD
Transmission	FS5W71C	
Number of speed	5	
Shift pattern		
Synchromesh type	Warner	
Gear ratio		
1st	3.321	3.985
2nd	1.902	2.246
3rd	1.308	1.415
4th	1.000	1.000
OD	0.838	0.821
Reverse	3.382	3.657
Number of teeth		
Mainshaft		
Drive	22	21
1st	33	34
2nd	27	28
3rd	26	26
OD	22	21
Reverse	36	36
Countershaft		
Drive	31	32
1st	14	13
2nd	20	19
3rd	28	28
OD	37	39
Reverse	15	15
Reverse idler gear	21	21
Oil capacity ℓ (US pt, Imp pt)	2.0 (4-1/4, 3-1/2)	4.9 (10-3/8, 8-5/8)
Remarks	Reverse synchronizer	
	—	2nd double baulk ring type synchronizer

GI

MA

EM

LC

EC

FE

CL

MT

AT

TF

PD

FA

RA

BR

ST

RS

BT

HA

EL

IDX

SERVICE DATA AND SPECIFICATIONS (SDS)

Inspection and Adjustment

GEAR END PLAY

Unit: mm (in)

1st gear	0.31 - 0.41 (0.0122 - 0.0161)
2nd gear	0.11 - 0.21 (0.0043 - 0.0083)
3rd gear	0.11 - 0.21 (0.0043 - 0.0083)
Overdrive gear	0.24 - 0.41 (0.0094 - 0.0161)

CLEARANCE BETWEEN BAULK RING AND GEAR

Unit: mm (in)

Standard	
1st & 2nd (2WD)	1.20 - 1.60 (0.0472 - 0.0630)
3rd & main drive	1.20 - 1.60 (0.0472 - 0.0630)
Overdrive	1.20 - 1.60 (0.0472 - 0.0630)
Reverse	1.10 - 1.55 (0.0433 - 0.0610)
Wear limit	
1st & 2nd (2WD)	0.80 (0.0315)
3rd & main drive	0.80 (0.0315)
Overdrive	0.80 (0.0315)
Reverse	0.70 (0.0276)

2nd baulk ring (4WD model)

Unit: mm (in)

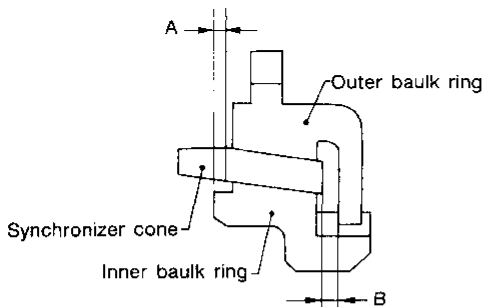

SMT733C

Dimension	Standard	Wear limit
A	0.7 - 0.9 (0.028 - 0.035)	0.2 (0.008)
B	0.6 - 1.1 (0.024 - 0.043)	

AVAILABLE SNAP RINGS

Main drive gear bearing

Allowable clearance		0 - 0.13 mm (0 - 0.0051 in)
Thickness	mm (in)	Part number
1.87	(0.0736)	32204-78001
1.94	(0.0764)	32204-78002
2.01	(0.0791)	32204-78003

Mainshaft front

Allowable clearance		0 - 0.18 mm (0 - 0.0071 in)
Thickness	mm (in)	Part number
2.4	(0.094)	32263-V5200
2.5	(0.098)	32263-V5201

Mainshaft rear end bearing (2WD model)

Allowable clearance		0 - 0.14 mm (0 - 0.0055 in)
Thickness	mm (in)	Part number
1.1	(0.043)	32228-20100
1.2	(0.047)	32228-20101
1.3	(0.051)	32228-20102
1.4	(0.055)	32228-20103

Counter drive gear

Allowable clearance		0 - 0.18 mm (0 - 0.0071 in)
Thickness	mm (in)	Part number
1.4	(0.055)	32215-E9000
1.5	(0.059)	32215-E9001
1.6	(0.063)	32215-E9002

SERVICE DATA AND SPECIFICATIONS (SDS)

Inspection and Adjustment (Cont'd)

AVAILABLE SHIMS

Countershaft front bearing

Unit: mm (in)

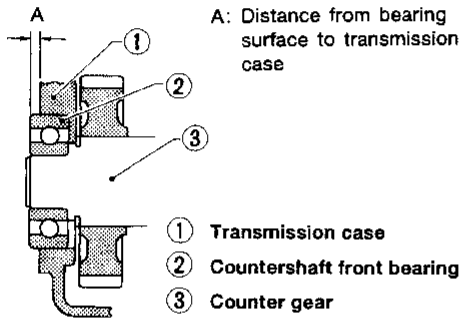

AMT092

"A"	Thickness of shim	Part number
4.52 - 4.71 (0.1780 - 0.1854)	Not necessary	
4.42 - 4.51 (0.1740 - 0.1776)	0.1 (0.004)	32218-V5000
4.32 - 4.41 (0.1701 - 0.1736)	0.2 (0.008)	32218-V5001
4.22 - 4.31 (0.1661 - 0.1697)	0.3 (0.012)	32218-V5002
4.12 - 4.21 (0.1622 - 0.1657)	0.4 (0.016)	32218-V5003
4.02 - 4.11 (0.1583 - 0.1618)	0.5 (0.020)	32218-V5004
3.92 - 4.01 (0.1543 - 0.1579)	0.6 (0.024)	32218-V5005

GI

MA

EM

LC

EC

FE

CL

MT

AT

TF

PD

FA

RA

BR

ST

RS

BT

HA

EL

IDX